

EasyBus3[®] SDATAWAY

Easy3-B24 – Technical documentation



- Fire damper and smoke detector controller
- Initial configuration with RFID label
- Maintenance / test with Bluetooth
- Color LEDs for easy status monitoring
- Magnetic fixation or single screw

Table of content

Table of content	2
1 Safety instructions	3
3 Device description	5
4 Technical characteristics	5
5 Electrical connections	6
5.1 Motor command (X1).....	7
5.2 Motor contacts (X2).....	8
5.3 Smoke detector (X3).....	9
5.4 EasyBus3® network.....	10
6 Functions	11
6.1 Basic behavior.....	11
6.2 Configuration label.....	12
6.3 Indication LEDs.....	13
6.4 Button.....	14
6.5 Bluetooth connectivity.....	15
6.6 Not commissioned function.....	15
6.7 Communication timeout.....	15
7 Mechanical fixation	16
8 Dimensions	17
9 Contact	18

1 Safety instructions

Please read the safety precautions carefully before EasyBus3® system installation and maintenance.

Please follow the instructions below.

- The installation or maintenance must accord with the instructions.
- Comply with all national electrical codes and local electrical codes.
- Pay attention to the warnings and cautions in this manual.
- All installation and maintenance shall be performed by distributor or qualified person.
- All electric work must be performed by a licensed technician according to local regulations and the instructions given in this manual.
- Be caution during installation and maintenance. Prohibit incorrect operation to prevent electric shock, casualty and other accidents.

The EasyBus3® system (including all EasyBus3® modules) must be:

- Installed, commissioned, maintained, repaired and removed by a qualified installer or qualified service person. When any of these jobs is to be done, ask a qualified installer or qualified service person to do them for you. A qualified installer or qualified service person is an agent who has the mandatory qualifications and appropriate knowledge to perform the task(s) required.

For all the tasks related to the 230VAC power supply:

- Installation and maintenance must be performed by a skilled electrical installer ensuring all legal and official regulations compliance.
- All wiring & connections must be done with the power off and according to the local energy supplier's instructions.

2 General Information

2.1 Compliance

The EasyBus3® system (include all EasyBus3® modules) complies with the following standards:

- 
- ✓ EN 60730-1
https://ec.europa.eu/eip/ageing/standards/home/sensors-actuators-and-alarms/en-60730_en
 - ✓ CENELEC EN50065-1
<https://www.cenelec.eu/standardsdevelopment/ourproducts/europeanstandards.html>



2.2 Disposal instructions



Unit Disposal Instructions

The EasyBus3® modules contain electronics. Please do not discard with regular waste. Return to SDATAWAY or dispose according to local guidelines for disposing of electronics. Dispose according to Waste Electrical and Electronic Equipment (WEEE) directive in European Union.

2.3 Symbol instructions

	<p>Electrical Shock or Burn Hazard (230 VAC)</p> <p>All electric work must be performed by a licensed technician according to local regulations and the instructions given in this manual.</p>
	<p>Caution Hot surface</p>
	<p>Warning to catch your attention to important points, the non-respect of these points could:</p> <ul style="list-style-type: none"> - Impact / Reduce the system functionalities. - Damage the modules and / or the entire installation.

2.4 Operating conditions

Minimum / Maximum ambient temperature:	5 – 40 °C
Humidity	0 – 95% RH, non-condensing
Operating	Indoor Use only

2.5 Storage and transport conditions

The EasyBus3® modules should be stored and transported in environmental conditions of -10°C to 60 °C, 0 to 95% RH, non-condensing.

2.6 Copyright ©

This documentation and its contents are the property of SDATAWAY SA.
Reproduction, in whole or in part, is permitted only for the use of EasyBus3® products.

The author and SDATAWAY SA are not responsible for any errors contained in this document and their potential consequences. These potential errors include errors in writing, translations and transcripts.

© 2018 SDATAWAY All Rights Reserved - Non-contractual pictures, technical specifications might change at any time.

3 Device description

The Easy3-B24 device is made to be controlled by an Easy3-M master device. Its function is to control and monitor a 24Vdc fire damper motor and/or a smoke detector module.

The module embeds all the EasyBus3® technology:

- Initial configuration using a RFID label
- Bluetooth connectivity for maintenance and test
- Color LEDs for visual monitoring
- Magnetic fixation for easy and flexible installation.

4 Technical characteristics

Description	Name	Min.	Typ.	Max.	Unit
Power supply characteristics					
Supply voltage	V _{EASY3-B24}		230		Vac
Power consumption, no-load	P _{EASY3-B24}		4		VA
			1.6		W
Power consumption, 0.3A max load	P _{EASY3-B24-MAX}		14		VA
			8.6		W
Motor control					
Motor command voltage	V _{MOTOR-CMD}		24	26.4	Vdc
Motor maximum power	P _{MOTOR}			10	VA
Motor contacts voltage	V _{MOTOR-IN}		24	26.4	Vdc
Motor contacts current	I _{MOTOR-INN}			1	mA
Smoke detector					
Smoke detector supply voltage	V _{DETECTOR}		24		Vdc
Smoke detector maximum power	P _{DETECTOR}			0.6	VA
Power-line communication					
Frequencies	f _{PLC}	100		240	kHz
Modulations	Mod		PSK/FSK		
Baud rate	-	2400		28800	Bps

5 Electrical connections

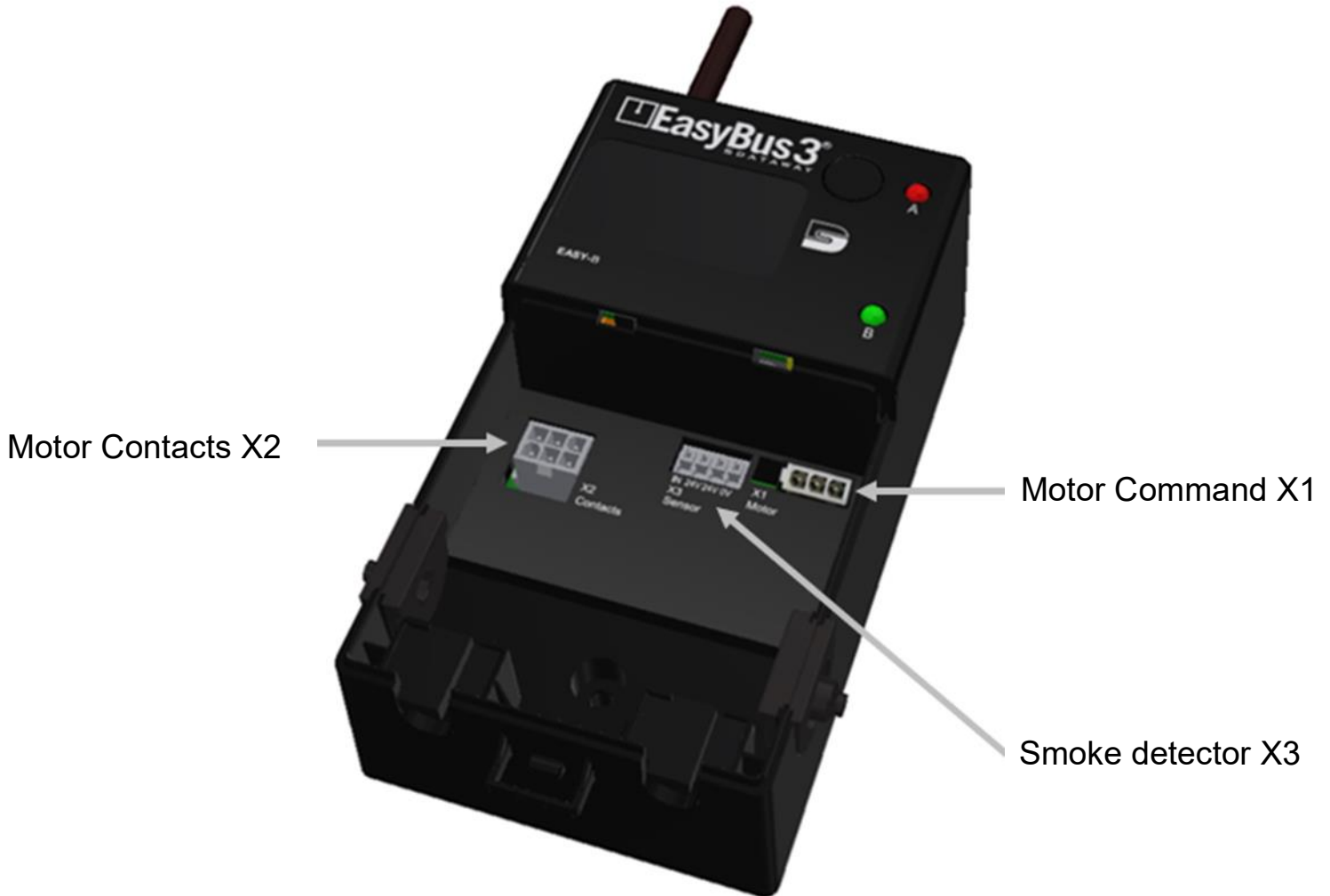

The motor command and motor contacts connectors are compatible with *Mate-N-Lok* connector type. The matching type must be assembled on the fire damper motor cables to ensure proper connection.

5.1 Motor command (X1)

The X1 electrical terminal is the interface connection between the Easy3-B24 module and the fire damper motor. It allows to command the opening and the closing of the motor.



Pin no.	Description
1	Open command
2	0V
3	Close command

Description	Min.	Nom.	Max.	Unit
Connector Type		Mate-N-Lok		
Power supply voltage		24	26.4	Vdc
Power supply current			0.3	A

5.2 Motor contacts (X2)

The X2 electrical terminal is the interface connection between the Easy3-B24 module and the motor contacts. It allows to monitor the motor position.

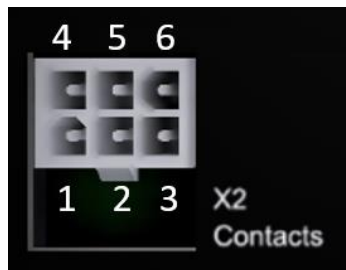

Pin no.	Description
4,3	Closed contact
2,5	Not connected
1,6	Open contact

Description	Min.	Nom.	Max.	Unit
Connector Type	Mate-N-Lok			
Power supply voltage		24	26.4	Vdc
Power supply current			1	mA

5.3 Smoke detector (X3)

The X3 electrical terminal is the interface connection between the Easy3-B24 module and the smoke detector. It allows to monitor the smoke detector signal.



If the smoke detector signal is cut, the fire damper command is automatically set to "close"
If no smoke detector is connected a wire must be connected between pins 1 and 2.



Pin no.	Description
1	Detector input signal
2,3	Detector power supply
4	0V

Typical connection of a smoke detector module:

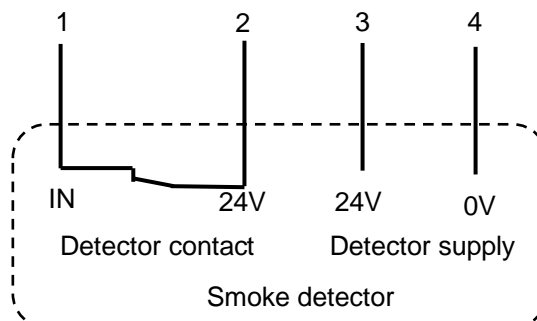

Description	Min.	Nom.	Max.	Unit
Power supply voltage		24	26.4	Vdc
Power supply current			25	mA
Wire size	0.2		1	mm ²

All Easy3-B24 are delivered with a wire connecting pins 1 and 2 to simulate a smoke detector.

5.4 EasyBus3® network

The device is preassembled with a 60cm cable to be connected to the EasyBus3® network.



Description	Min.	Nom.	Max.	Unit
Supply voltage		230		Vac
Supply power			45 26	VA W
Wire size		1.32		mm ²
Cable length		60		cm



The EasyBus3® network is connected to the mains network 230 Vac. All connections on the EasyBus3® network must use suitable connectors.



The EasyBus3® Sub-Networks are proprietary power line networks communications.

Only EasyBus3® products must be installed on these networks.



The addition of supplementary non-compatible products may lead to damage to the modules and / or the entire installation.

EasyBus3® Sub-Network(s) cannot be used as power supply network(s). It is strictly forbidden to install T13 plugs to supply other equipment.

6 Functions

6.1 Basic behavior

The diagram below shows the basic behavior with the different states of the system. The arrows indicate the transitions between the states, they are described in the table below.

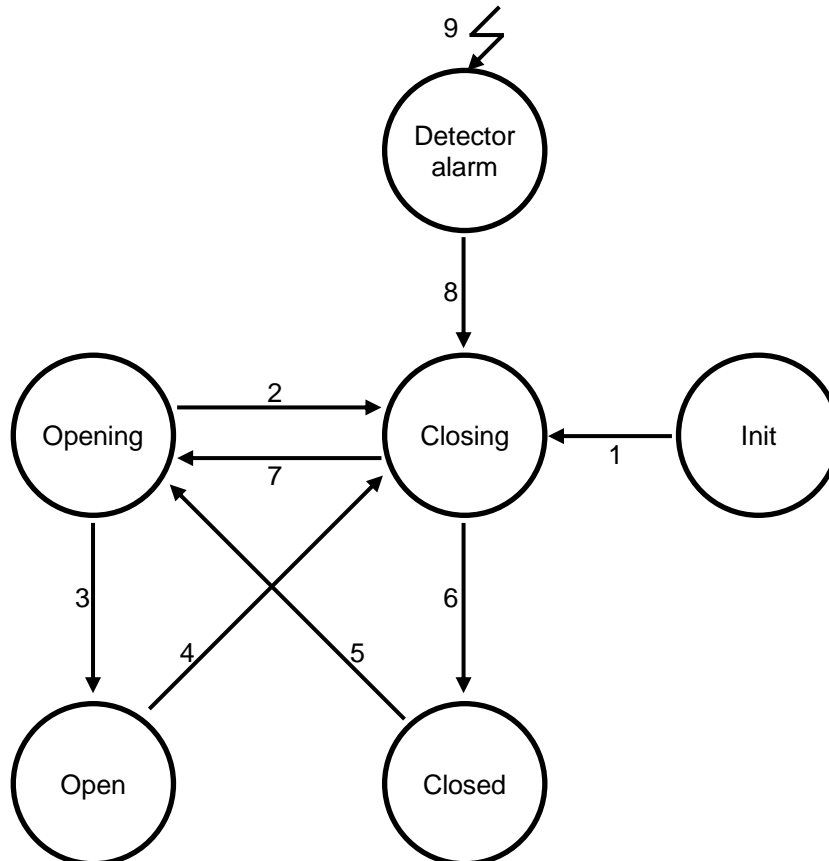

No	Description
1	System initialized
2,4	Command changed from <i>open</i> to <i>close</i>
3	Open contact detected
5,7	Command changed from <i>close</i> to <i>open</i>
6	Closed contact detected
8	The detector alarm contact is back to normal
9	The detector alarm changed to error

6.2 Configuration label

The EasyBus3® address configuration **must** be made by using a specific RFID label.

The label must be applied in the dedicated area shown in the picture below:



If the Easy3-B24 module is not equipped with a RFID tag and/or if it has not been addressed manually via Bluetooth, it will not be recognized by the EasyBus3® system.

6.3 Indication LEDs

Two indication LEDs are available:

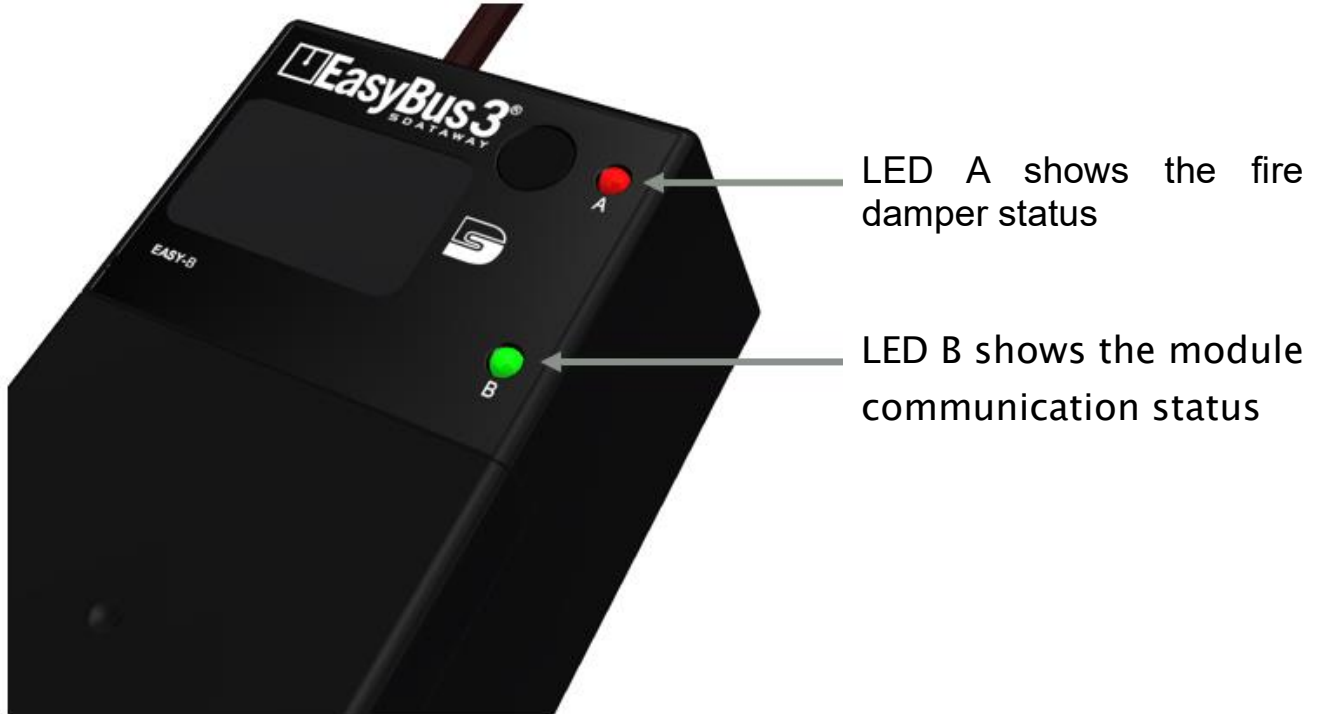

Fire Damper Status	LED A
Initialization	White
Motor opening	Blinking green
Motor open	Green
Motor closing	Blinking red-green
Motor closed	Green short pulse
Smoke detector alarm	Blinking red

Module Status (Com)	LED B
Communication event	1 pulse green
Communication error	Red
Bluetooth active	Blinking blue
Bluetooth connected	Blue
Highlight network	White

6.4 Button

The button main function is to enable the Bluetooth connectivity.

Please refer to chapter 6.5 Bluetooth connectivity for detailed information.

One short press on the button activates the Bluetooth connectivity during one minute.



Module decommissioning via the button:

The button can also be used to decommissioned the device. The following sequence must be followed:

1. Press and hold the button for 5 seconds
2. All LEDs will turn to white to confirm the reset action
3. Release the button

6.5 Bluetooth connectivity

A smartphone application compatible with Apple iOS and Android systems is required to connect to a device.

The Bluetooth connectivity is always turned OFF and must be activated by either pressing the device button or remotely using the Easy-H interface.

Once connected, the following actions are possible:

- Read the device status
- Read statistics counters
- Configure the device address and frequency
- Manual open/close control to test the installation



6.6 Not commissioned function

When the device is connected to the mains for the first time, or after a decommissioning (*Please refer to chapter 6.4 for detailed information*), it is in the “not commissioned” state.

In this state, the fire damper motor is opened automatically in order to easily test the installation.

As soon as the device is configured by the Easy3-H + Easy3-M, it will not open the fire damper automatically anymore.

6.7 Communication timeout

If the Easy3-B24 does not receive any valid frame during **1 minute**, it will automatically close the fire damper motor to ensure that the system is in a safe state.

7 Mechanical fixation

Two strong magnets are placed in the plastic case and are designed to ensure the fixation on any metallic surface. The fixation force may vary depending on the metal plate material property.

If for any reason the magnetic fixation is not sufficient, it is possible to fix the device with a screw. The screw hole is located below the protection cover. The hole dimension and position are shown in the picture below.

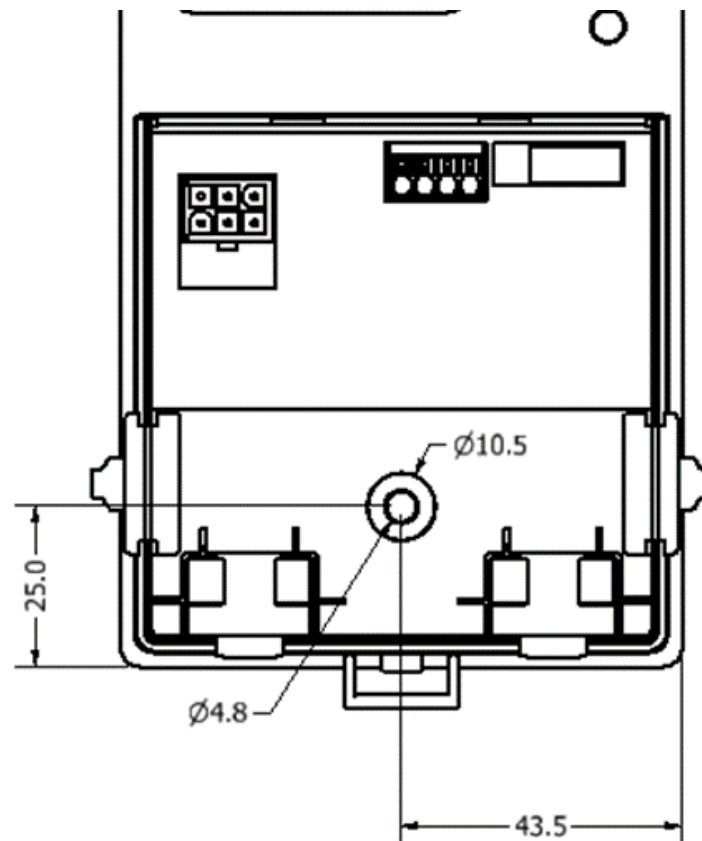

8 Dimensions

EasyBus3[®] Easy3-B24 dimensions

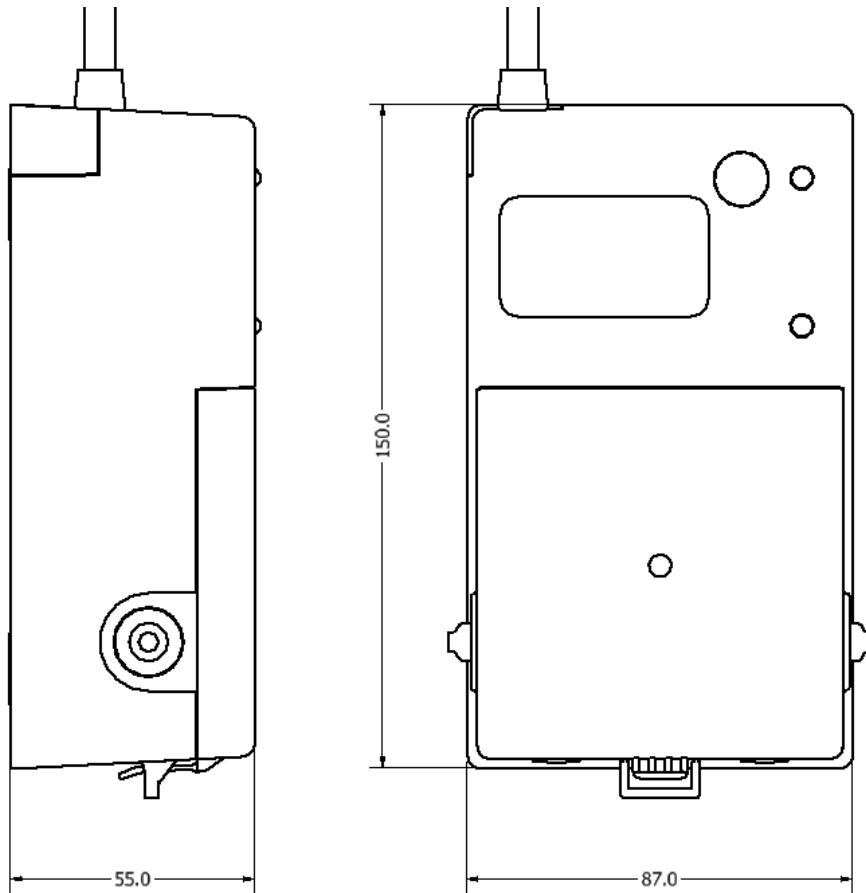

9 Contact

Please visit our website to get all the EasyBus3[®] information and to download the latest version of this manual.

www.easybus3.com
support.easybus3.com

Scan here to download the latest version of the EasyBus3[®] system technical manuals.

