



Multileaf dampers

Type JZ-* in Ex-construction

TROX GmbH
Heinrich-Trox-Platz
47504 Neukirchen-Vluyn
Germany
Phone: +49 2845 2020
Fax: +49 2845 202265
E-mail: trox-de@troxgroup.com
http://www.troxtechnik.com

Product overview

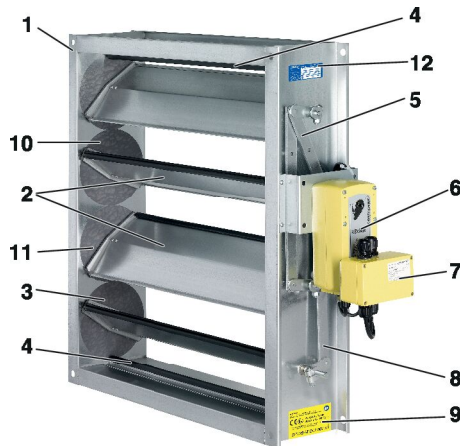

Fig. 1: Schematic illustration, example JZ-HL

- | | | | |
|---|---|----|---|
| 1 | Casing | 7 | Explosion-proof terminal box |
| 2 | Opposed blades (for JZ-P*: parallel blades) | 8 | External linkage |
| 3 | Blade tip seal (only for JZ-HL*, JZ-LL-*) | 9 | Sticker showing approved zones with potentially explosive atmospheres |
| 4 | Travel stop (angle section with seal) (JZ-HL*, JZ-LL-*, only) | 10 | Slide disc (only for JZ-LL-*) |
| 5 | Transverse link | 11 | Blade seal, face side (only for JZ-LL-*) |
| 6 | Explosion-proof actuator (optional) | 12 | Rating plate |

Variants of the type JZ

Standard - JZ-S, JZ-P, JZ-S-A2, JZ-P-A2

Low leakage - JZ-HL, JZ-LL, JZ-LL-A2

Important notes

Information on the installation manual

This manual enables operating or service personnel to correctly install the product described below and to use it safely and efficiently.

It is essential that these individuals read and fully understand this manual before starting any work. The basic prerequisite for safe working is to comply with the safety notes and all instructions in this manual.

The local regulations for health and safety at work and general safety regulations also apply.

Other applicable documentation

In addition to these instructions, the following documents apply:

- Technical data of the product brochure multi-leaf damper
- Technical data of the product brochure attachments
- Safety data sheets and operating instructions for the attachments
- ATEX Certificate of Conformity EPS 23 ATEX 2 307 X

Staff qualifications

The work described in this manual has to be carried out by individuals with the qualification, training, knowledge and experience described below:

HVAC technician

HVAC technicians are individuals who have sufficient professional or technical training in the field they are working in to enable them to carry out their assigned duties at the level of responsibility allocated to them and in compliance with the relevant guidelines, safety regulations and instructions. HVAC technicians are individuals who have in-depth knowledge and skills related to HVAC systems; they are also responsible for the professional completion of the work under consideration.

HVAC technicians are individuals who have sufficient professional or technical training, knowledge and actual experience to enable them to work on HVAC systems, understand any potential hazards related to the work under consideration, and recognise and avoid any risks involved.

Skilled qualified electrician

Skilled qualified electricians are individuals who have sufficient professional or technical training, knowledge and actual experience to enable them to work on electrical systems, understand any potential hazards related to the work under consideration, and recognise and avoid any risks involved.



Working in areas with potentially explosive atmospheres

The system owner may require that work in areas with potentially explosive atmospheres is carried out by individuals with additional qualifications. All work must be approved by the system operator before commencing.

Limitation of liability

The information in this manual has been compiled with reference to the applicable standards and guidelines, the state of the art, and our expertise and experience of many years.

The manufacturer does not accept any liability for damages resulting from:

- Non-compliance with this manual
- Incorrect use
- Operation or handling by untrained individuals
- Unauthorised modifications

The actual scope of delivery may differ from the information in this manual for special constructions, additional order options or as a result of recent technical changes.

Copyright

This document, including all illustrations, photos, etc., is protected by copyright.

This manual may not be made available to third parties, reproduced in any form or by any means, not even in extracts, nor may its contents be utilised and/or communicated without the written consent of the manufacturer.

Violators will be held liable for any damage. The right to further claims remains reserved.

Personal protective equipment

Personal protective equipment must be worn for any work in order to reduce health or safety hazards to the minimum.

The appropriate protective equipment for a job must be worn for as long as the job takes.

Explosion protection



WARNING!

Explosion hazard from electrostatic charges!

In potentially explosive atmospheres, electrostatic charging of persons and non-metallic components must be avoided.

To avoid electrostatic charges, the following must be observed:

- Wear anti static protective clothing, like dissipative shoes, clothes, gloves etc.
- If using tools, comply with DIN EN 1127-1, appendix A.

The work area should ideally have anti static flooring.

Correct use

The multileaf damper is used as an actuator for volume flow and pressure control in ventilation and air conditioning systems, e.g. e.g. in ventilation and air conditioning units, in ventilation centres or air ducts in potentially explosive atmospheres.

Explosion-proof multileaf dampers are labelled on the type plate in accordance with ATEX Directive 2014/34/EU. The multileaf dampers may only be used in the Ex zones defined by the device category.

Correct use also involves complying with all the information provided in this manual. Any use that goes beyond the correct use or any different use of the unit is regarded as incorrect use.

Use in areas with potentially explosive atmospheres (ATEX)

In accordance with the Certificate of Conformity EPS 23 ATEX 2 307 X, the multileaf damper can be used in the following Ex zones:

⚡ ⚡ II 2G Ex h IIC T6 ...T4 Gb

⚡ ⚡ II 2D Ex h IIC T80 °C ... T130 °C Db

The approved Ex area is indicated on the multileaf damper.

The ambient temperatures specified in the technical data and the attachments must be considered, [☞ 7.1 'ATEX areas of application' on page 14](#)



WARNING!

Danger due to incorrect use!

Incorrect use of the unit can lead to dangerous situations:

- in an Ex area for which it has not been approved
- for transporting media with unauthorised high or low temperatures, [☞ Chapter 7 'Technical data' on page 12.](#)
- near:
 - strong electromagnetic fields
 - high frequency sources (e.g. transmitting stations)
 - strong light sources (e. g. laser beams)
 - ionising radiation (e.. g. X-ray tubes)
 - ultrasonic sources (e. g. ultrasonic echo test equipment)

Never use the unit:

- for regulating and shutting off process air
- outdoors without sufficient protection against the effects of weather
- in humid rooms
- in rooms with aggressive room air components, e. g. sand

Loss of explosion protection



WARNING!

Explosion protection!

For units intended for installation in systems for operation in potentially explosive atmospheres in accordance with Directive 2014/34/EU, the operator must ensure compliance with the directive for the entire system.

Failure to comply will result in loss of explosion protection.

Standards and guidelines

The essential health and safety requirements of Directive 2014/34/EU are met by conformity with the following standards:

- EN 1127-1 - Explosive atmospheres - Explosion protection: Basic concepts and methodology
- DIN EN ISO 80079-36 - Explosive atmospheres: Non-electrical equipment for use in potentially explosive atmospheres - Basic concepts and requirements
- DIN EN ISO 80079-37 - Explosive atmospheres: Non-electrical equipment for use in potentially explosive atmospheres - Protection by constructional safety 'c'

Transport and packaging

Transport



CAUTION!

Danger of injury from sharp edges, sharp corners and thin sheet metal parts!

Sharp edges, sharp corners and thin sheet metal parts may cause cuts or grazes.

- Be careful when carrying out any work.
- Wear protective gloves, safety shoes and a hard hat.

Explosion protection



WARNING!

Loss of explosion protection due to transport damage!

Goods damaged during transport may lead to a loss of explosion protection. If upon delivery any damage is visible, inform the manufacturer. Do not commission the unit.

Failure to comply with this note will result in the loss of explosion protection.

Use only lifting and transport gear designed for the required load. During transport, always secure the load against tipping and falling.

After delivery, carefully remove the packaging and check the unit for transport damage and completeness.

Storage

Please note:

- Store the product only in its original packaging
- Protect the product from the effects of weather
- Protect the product from humidity, dust and contamination
- Storage temperature: -10 °C to 50 °C.
- Relative humidity: 95% max., no condensation

Installation

General safety notes



CAUTION!

Danger of injury from sharp edges, sharp corners and thin sheet metal parts!

Sharp edges, sharp corners and thin sheet metal parts may cause cuts or grazes.

- Be careful when carrying out any work.
- Wear protective gloves, safety shoes and a hard hat.

Ex WARNING!

Risk of explosion!

Ignition sources, such as sparks, naked flames or hot surfaces, can lead to explosions in an area with potentially explosive atmospheres.

- Only specially trained personnel may carry out work in an area with potentially explosive atmospheres.
- Get written permission before starting any work in an area with potentially explosive atmospheres.
- Work may only be carried out if there is no potentially explosive atmosphere or if ignition sources are avoided. In particular, make sure that all work equipment is approved for the relevant Ex zone.

Failure to comply with these safety instructions will result in loss of explosion protection.

! NOTICE!

Contamination or damage will impair the function of the multileaf damper.

During installation, protect the multileaf damper from contamination and damage.

Personnel:

- HVAC technician

General installation information

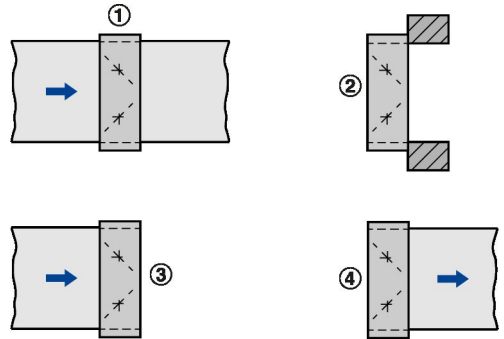

Fig. 2: Installation types

- ① Ducts on both sides
- ② without duct (air transfer flow)
- ③ Air duct on one side (air outlet)
- ④ Air duct on one side (air inlet)

The multileaf damper can be installed away from walls (in air ducts), or directly in front of or on walls and ceilings.

Please note:

- Installation should be vertical and without torsion
- Installation in vertical or horizontal air ducts
- Installation only with horizontal blades
- Any airflow direction
- Duct connection on one side or on both sides
- The function of the damper must be checked before installation.

! CAUTION!

Danger of injury!

Danger of injury when reaching into the blades or the linkage of the multileaf damper.

Once the multileaf damper has been installed, people must be prevented from reaching into the damper, for example by installation of a cover grille.

! NOTICE!

Temperatures below the dew point

Temperatures below the dew point should be avoided as they lead to condensation which may cause damage to the building structure.

Duct installation

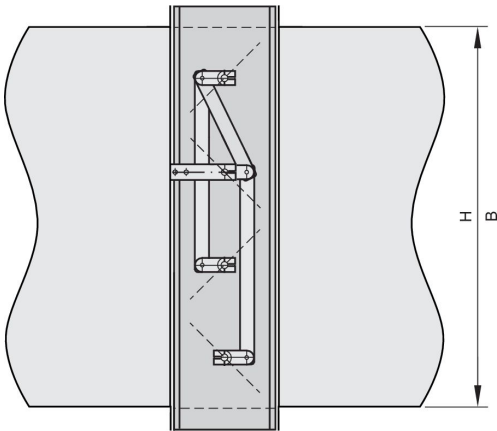

Fig. 3: Duct installation

Use screws (by others) to fix the multileaf damper to the duct. Due to its weight the multileaf damper must be supported, e.g. by a suspension system.

Wall/ceiling installation

Screw fix installation

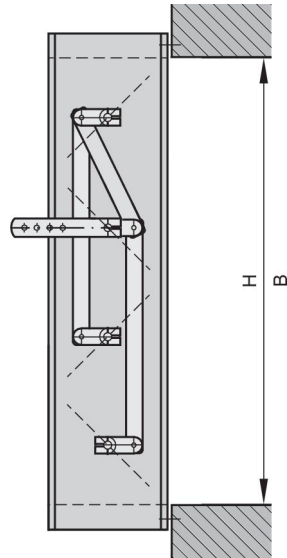

Fig. 4: Wall installation

Use suitable screws (by others) to attach the multileaf damper to the wall or ceiling slab.

Installation with installation subframe

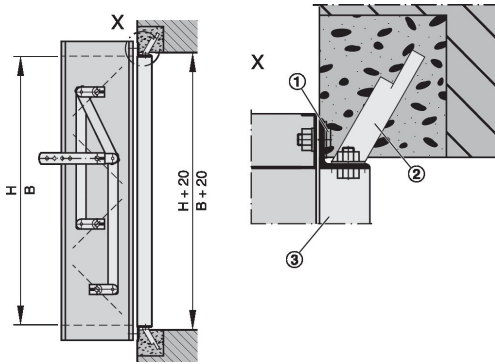

Fig. 5: Wall installation with installation subframe (steel/stainless steel construction)

- ① Threaded stud
- ② Fixing tab
- ③ Installation subframe

Items 1 to 3 are included in the installation subframe supply package

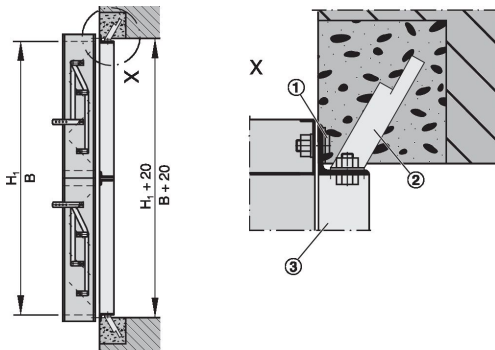

Fig. 6: Wall installation with installation subframe (steel/stainless steel construction), height subdivided

H₁ See ↗ 'Dimensions of JZ-*' on page 12

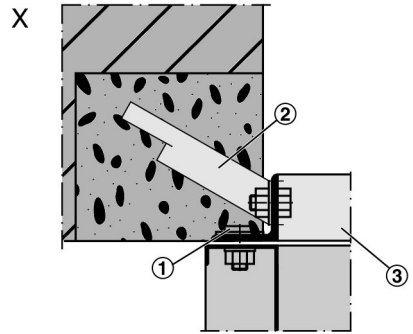
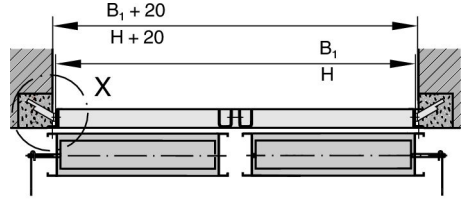

Fig. 7: Wall installation with installation subframe (steel/stainless steel construction), width subdivided

B₁ See ↗ 'Dimensions of JZ-*' on page 12

Assembly of installation subframe

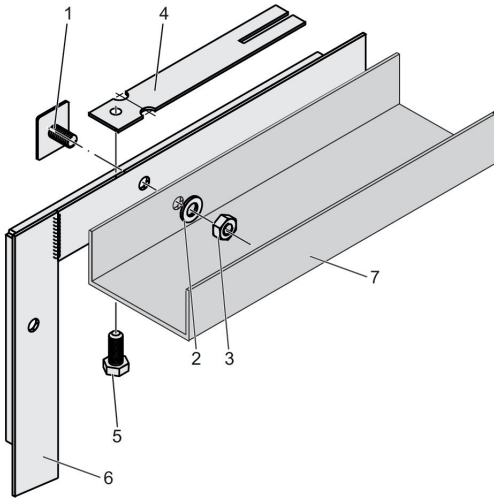

Fig. 8: Installation subframe and damper assembly

- ① Threaded stud
- ② Washer
- ③ Hexagon nut
- ④ Fixing tab
- ⑤ Hexagon head screw
- ⑥ Installation subframe
- ⑦ Casing of the multileaf damper

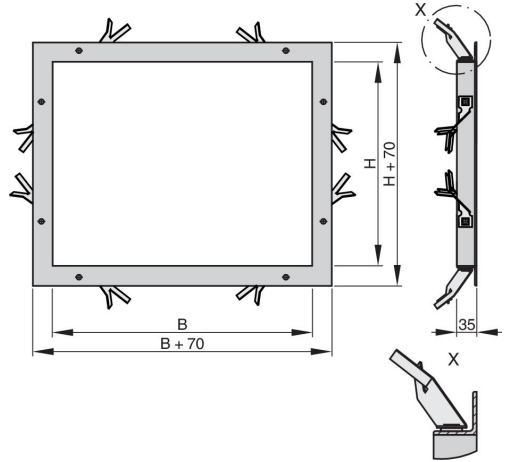

Fig. 9: Bend and spread the fixing tabs before installation

Connecting the air duct

Use screws to attach the damper to the ducting. The damper casing has flange holes for duct connection.

Seal the joint between the casing flange and the duct in order to avoid pressure loss. Use sealing tape, for example, and clamps or additional screws, if necessary.



The movement of the damper blades must not be obstructed by any attachment.



CAUTION!

Danger of injury when reaching into the multileaf damper.

If only one end is to be ducted, the other end must be secured on site by a cover grille against reaching into the multileaf damper (galvanised steel, mesh aperture ≤ 20 mm), or by an external weather louvre.

Potential equalisation

The multileaf damper must be connected to the earth bar by a qualified electrician. Potential equalisation prevents electrostatic ignition hazards.

Execution of potential equalisation (on-site):

- Single-wire CU cable 6 mm² with ring cable lug.
- The connection must be self-locking (secured against self-loosening).

Electrical/pneumatic connection

Actuators provided by others

Multileaf dampers for use in areas with potentially explosive atmospheres must not be fitted or retro-fitted with actuators provided by others.

Installation according to ATEX

Explosion protection



WARNING!

Risk of explosion!

Observe the following points for the initial commissioning of explosion-protected devices:

- Get written permission before starting any work in an area with potentially explosive atmospheres.
- Carry out commissioning and any test run only after you have ensured that there is no potentially explosive atmosphere.

Failure to comply with these safety instructions will result in loss of explosion protection.

- The cables to be used must comply with ATEX standards.
- The type of protection of the unit must not be compromised by the connection of pipes, cables etc.
- Regardless of the type of protection, only cables that have been tested and certified in accordance with the technical regulations may be used.
- The connections are made in an explosion-proof terminal box that has been certified for the relevant zones.
- No loose terminals must be used in the terminal box.
- Once you have connected the cables, tighten the cable glands firmly in order to ensure IP protection (IP 66).
- In areas with potentially explosive atmospheres, unused openings for cable penetration must be sealed with certified blind plugs.

Connecting the electric actuator

Personnel:

- Skilled qualified electrician

Use only cables that are designed for the supply voltage for which they will be used. The power rating is given on the actuator rating plate. Furthermore, cable lengths, cable cross-sections and contact resistances influence possible voltage losses.

A qualified electrician has to select the correct cable types and sizes.



DANGER!

Danger of electric shock! Do not touch any live components! Electrical equipment carries a dangerous electrical voltage.

- Only skilled qualified electricians are allowed to work on the electrical system.
- Switch off the power supply before working on any electrical equipment.

- ▶ Connect the actuator to the explosion-proof terminal box as indicated on the actuator or in the manufacturer's product documentation.

Explosion-proof electric actuators

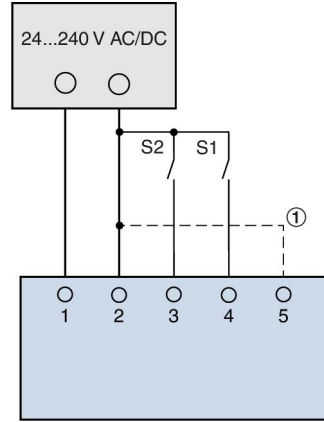

Fig. 10: 2-wire control

- ① Wire link between terminals 2 and 5: Spring return ~3s (only ExMax15-SF)
- S1 open and S2 open: Actuator has stopped (any position)
- S1 closed: Direction of rotation 1
- S1 open and S2 closed: Direction of rotation 2

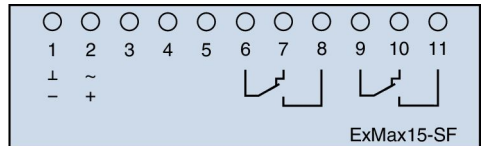

Fig. 11: Terminal connections in terminal box ExMax15-SF

- 1 ⊥, -
- 2 ~, +
- 3 Control voltage for direction of rotation 1
- 4 Control voltage for direction of rotation 2
- 5 Input for wire link terminal 2-5: spring return ~3 s
- 6 Common contact
- 7 Travel stop 1 < 5°
- 8 Travel stop 1 > 5°
- 9 Common contact
- 10 Travel stop 2 < 85°
- 11 Travel stop 2 > 85°

If both auxiliary switches are used, the switching voltages must be the same.

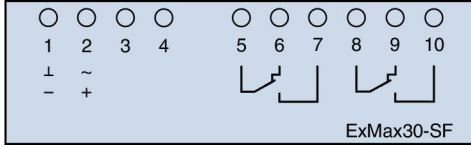

Fig. 12: Terminal connections in terminal box ExMax30-SF

- 1 ⊥, -
- 2 ~, +
- 3 Control voltage for direction of rotation 1
- 4 Control voltage for direction of rotation 2
- 5 Common contact
- 6 Travel stop 1 < 5°
- 7 Travel stop 1 > 5°
- 8 Common contact
- 9 Travel stop 2 < 85°
- 10 Travel stop 2 > 85°

If both auxiliary switches are used, the switching voltages must be the same.

Explosion-proof pneumatic actuators

Personnel:

- Skilled qualified electrician

Requirements

- Control medium: dust, oil-free and dry air as well as inert gases
- Supply voltage, depending on the solenoid valve, see rating plate.
- Operating pressure, depending on the actuator, see rating plate.

⚠ DANGER!

Danger of electric shock! Do not touch any live components! Electrical equipment carries a dangerous electrical voltage.

- Only skilled qualified electricians are allowed to work on the electrical system.
- Switch off the power supply before working on any electrical equipment.

1. ▶ Connect the solenoid valve as indicated on the valve or the manufacturer's product documentation.
2. ▶ Connect the tubes according to the tubing diagram.

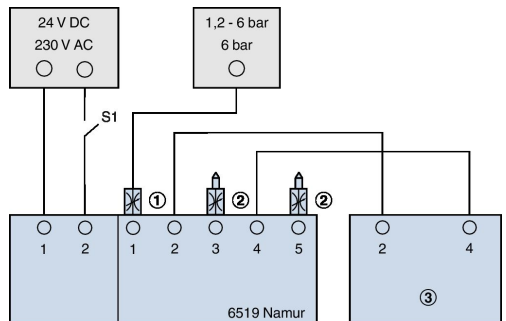

Fig. 13: Pneumatic actuator with solenoid valve

- ① Throttle valve
- ② Flow reducer (noise reduction)
- ③ Double acting or single acting actuator

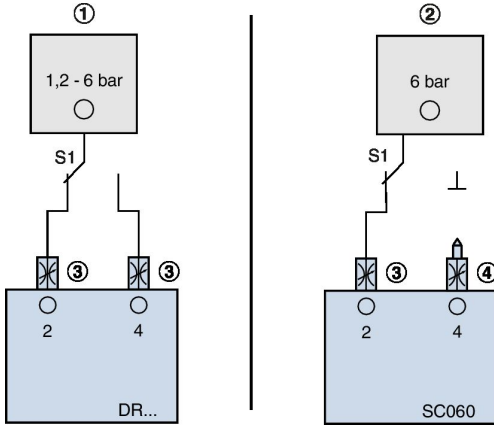

Fig. 14: Pneumatic actuator without solenoid valve

- ① Double acting pneumatic actuator
- ② Single acting pneumatic actuator
- ③ Throttle valve
- ④ Flow reducer (noise reduction)

Limit switch

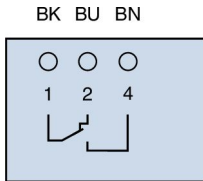

Fig. 15: Connecting cable core identification for limit switch

- 1 Common contact
- 2 NC contact
- 4 NO contact

Commissioning and maintenance

Commissioning

Personnel:

- HVAC technician

1. ▶ As part of commissioning of the ventilation system, a functional test of the multileaf damper must be carried out, and it must be checked whether the requirements for use in potentially explosive atmospheres for the relevant zone are met.
2. ▶ Set the auxiliary switch as part of the function test.

Maintenance

The multileaf damper and the actuator are low-maintenance with regard to wear and tear, but multileaf dampers must still be included in the regular cleaning of the ventilation system.

Technical data

Multileaf dampers are manufactured according to the width (B) × height (H) ordered.

The multileaf dampers must be installed according to B × H.

Dimensions of JZ-*

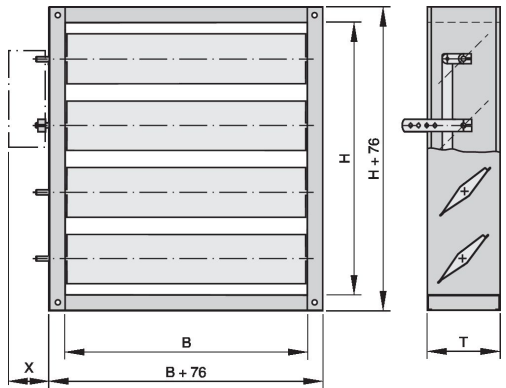

Fig. 16: JZ-*

T 180 mm for steel/stainless steel construction

Attachments	Dimension X [mm]
Z1EX, Z60EX - Z77EX	200
Z3EX	300

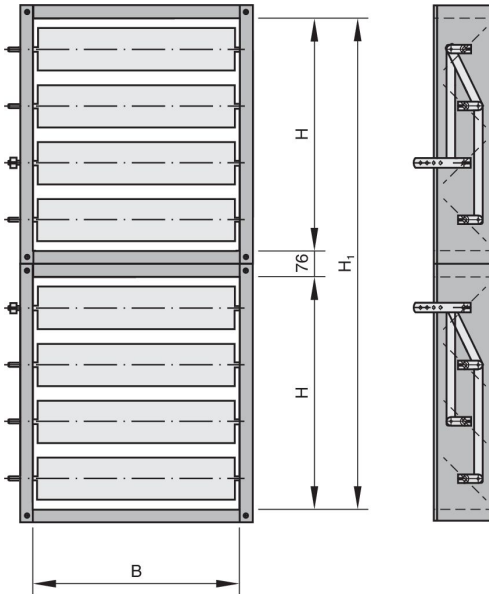

Fig. 17: JZ with height subdivided

$$H_1 = 2 H + 76 \text{ mm}$$

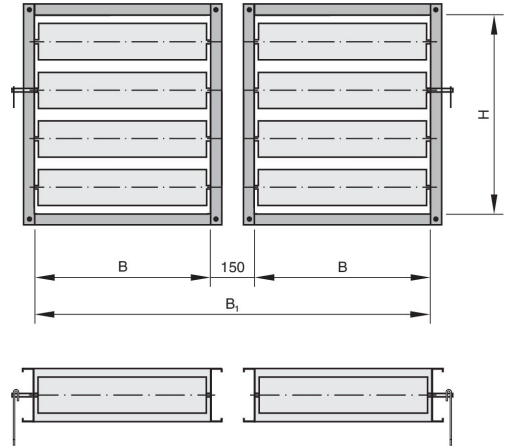

Fig. 18: JZ with width subdivided

$$B_1 = 2 B + 150 \text{ mm}$$

	JZ-S	JZ-P	JZ-S-A2	JZ-P-A2	JZ-LL	JZ-HL	JZ-LL-A2
Steel, galvanised	•	•			•	•	
Stainless steel			•	•			•
Aluminium							
Parallel		•		•			
Opposed	•		•		•	•	•
Closed blade air leakage according to EN 1751 (class)					3 - 4	1 - 2	3 - 4
Casing air leakage according to EN 1751 (class)				C			
Maximal airflow velocity in free cross-sectional area				8 m/s			
Temperature resistance (media temperature)		-20...150 °C				0...100 °C	

For further technical data, see product brochure and technical data sheets for attachments.

ATEX areas of application

The ATEX application areas depend on the Ex actuator used and the ambient temperature

Explosion-proof electric actuators

Order code detail	Type of actuation	Labelling	Ambient temperature	Maximum Airflow velocity
Z1EX	ExMax-15-SF	II 2G Ex h IIC T6 Gb II 2D Ex h IIIC T80°C Db	-20°C ≤ Ta ≤ +40°C	8 m/s
Z3EX	ExMax-30-SF	II 2G Ex h IIC T6 Gb II 2D Ex h IIIC T80°C Db	-20°C ≤ Ta ≤ +40°C	8 m/s
Z***EX	upon request	II 2G Ex h IIC T5 Gb II 2D Ex h IIIC T95°C Db	-20°C ≤ Ta ≤ +50°C	8 m/s
Z***EX	upon request	II 2G Ex h IIC T4 Gb II 2D Ex h IIIC T130°C Db	-20°C ≤ Ta ≤ +60°C	8 m/s

Explosion-proof pneumatic actuators

Order code detail	Type of actuation	Labelling	Ambient temperature	Maximum Airflow velocity
Z60EX	double-acting 35 Nm; without limit switch	II 2G Ex h IIC T6 Gb II 2D Ex h IIIC T80°C Db	-20°C ≤ Ta ≤ +40°C	8 m/s
Z61EX	double-acting 35 Nm; without limit switch, solenoid valve 24V	II 2G Ex h IIC T6 Gb II 2D Ex h IIIC T80°C Db	-20°C ≤ Ta ≤ +40°C	8 m/s
Z62EX	double-acting 35 Nm; without limit switch, solenoid valve 230V	II 2G Ex h IIC T6 Gb II 2D Ex h IIIC T80°C Db	-20°C ≤ Ta ≤ +40°C	8 m/s
Z63EX	double-acting 35 Nm; 2x limit switch	II 2G Ex h IIC T6 Gb II 2D Ex h IIIC T80°C Db	-20°C ≤ Ta ≤ +40°C	8 m/s
Z64EX	double-acting 35 Nm; 2x limit switch, solenoid valve 24V	II 2G Ex h IIC T6 Gb II 2D Ex h IIIC T80°C Db	-20°C ≤ Ta ≤ +40°C	8 m/s
Z65EX	double-acting 35 Nm; 2x limit switch, solenoid valve 230V	II 2G Ex h IIC T6 Gb II 2D Ex h IIIC T80°C Db	-20°C ≤ Ta ≤ +40°C	8 m/s
Z66EX	double-acting 70 Nm; without limit switch	II 2G Ex h IIC T6 Gb II 2D Ex h IIIC T80°C Db	-20°C ≤ Ta ≤ +40°C	8 m/s
Z67EX	double-acting 70 Nm; without limit switch, solenoid valve 24V	II 2G Ex h IIC T6 Gb II 2D Ex h IIIC T80°C Db	-20°C ≤ Ta ≤ +40°C	8 m/s
Z68EX	double-acting 70 Nm; without limit switch, solenoid valve 230V	II 2G Ex h IIC T6 Gb II 2D Ex h IIIC T80°C Db	-20°C ≤ Ta ≤ +40°C	8 m/s
Z69EX	double-acting 70 Nm; 2x limit switch	II 2G Ex h IIC T6 Gb II 2D Ex h IIIC T80°C Db	-20°C ≤ Ta ≤ +40°C	8 m/s
Z70EX	double-acting 70 Nm; 2x limit switch, solenoid valve 24V	II 2G Ex h IIC T6 Gb II 2D Ex h IIIC T80°C Db	-20°C ≤ Ta ≤ +40°C	8 m/s

Order code detail	Type of actuation	Labelling	Ambient temperature	Maximum Airflow velocity
Z71EX	double-acting 70 Nm; 2x limit switch, solenoid valve 230V	II 2G Ex h IIC T6 Gb II 2D Ex h IIIC T80°C Db	-20°C ≤ Ta ≤ +40°C	8 m/s
Z72EX	single-acting 30 Nm; without limit switch	II 2G Ex h IIC T6 Gb II 2D Ex h IIIC T80°C Db	-20°C ≤ Ta ≤ +40°C	8 m/s
Z73EX	single-acting 30 Nm; without limit switch, solenoid valve 24V	II 2G Ex h IIC T6 Gb II 2D Ex h IIIC T80°C Db	-20°C ≤ Ta ≤ +40°C	8 m/s
Z74EX	single-acting 30 Nm; without limit switch, solenoid valve 230V	II 2G Ex h IIC T6 Gb II 2D Ex h IIIC T80°C Db	-20°C ≤ Ta ≤ +40°C	8 m/s
Z75EX	single-acting 30 Nm; 2x limit switch	II 2G Ex h IIC T6 Gb II 2D Ex h IIIC T80°C Db	-20°C ≤ Ta ≤ +40°C	8 m/s
Z76EX	single-acting 30 Nm; 2x limit switch, solenoid valve 24V	II 2G Ex h IIC T6 Gb II 2D Ex h IIIC T80°C Db	-20°C ≤ Ta ≤ +40°C	8 m/s
Z77EX	single-acting 30 Nm; 2x limit switch, solenoid valve 230V	II 2G Ex h IIC T6 Gb II 2D Ex h IIIC T80°C Db	-20°C ≤ Ta ≤ +40°C	8 m/s

Replacement parts



WARNING!

Risk of injury from the use of incorrect replacement parts!

Incorrect or faulty replacement parts pose a risk to health and safety, and their use can cause malfunction, damage to property and total failure of equipment.

- Use only genuine replacement parts from the manufacturer or replacement parts that the manufacturer has approved.
- When in doubt, contact the manufacturer.



Void of warranty

Using non-approved replacement parts will void your product's warranty.

Buy replacement parts from an authorised supplier or from the manufacturer. For contact details see page 2.

Explosion protection



WARNING!

Risk of explosion from the use of incorrect replacement parts!

Using incorrect or faulty replacement parts in areas with potentially explosive atmospheres can lead to an explosion. This can cause serious or even fatal injuries as well as considerable damage to property.

Therefore:

- Use only genuine replacement parts from the manufacturer or replacement parts that the manufacturer has approved.
- When in doubt, contact the manufacturer.

Failure to comply with these safety instructions will result in loss of explosion protection.



Loss of warranty

Using non-approved replacement parts will void your manufacturer's warranty.

Buy replacement parts from an authorised supplier or directly from the manufacturer. For contact details, see page 2.